

N-Stück-Losflansch Flanschenfußkrümmer nach DIN EN 1092-2 Typ 16
Flanged 90° duckfoot bend with loose flanges conform DIN EN 1092-2 type 16

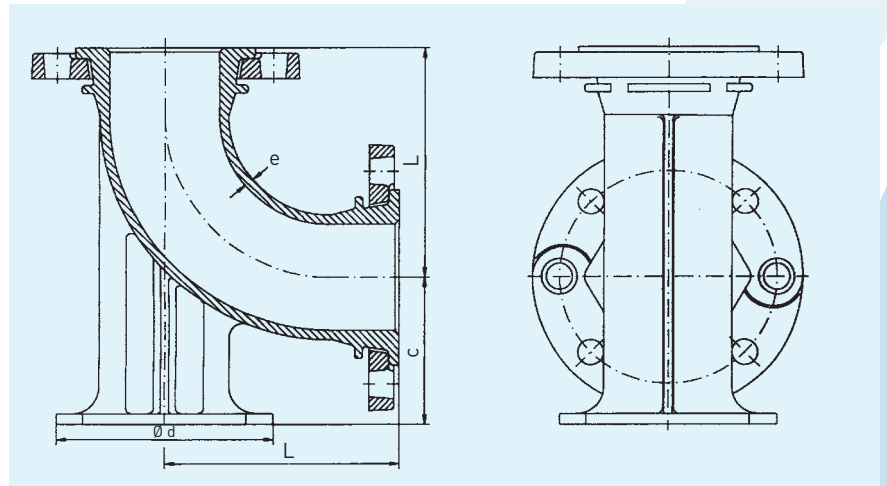

Maße in mm · dimensions in mm					kg/Stück kg/piece
DN	L	c	d	e	
80	165	110	160	7,0	12,7
100	180	125	200	7,2	15,7

Werkstoff: Duktiles Gusseisen GJS (GGG)
 Beschichtung: EWS-beschichtet nach RAL-GZ-662

Material: Ductile cast iron GJS (GGG)
 Coating: EWS-(fusion bonded epoxy) coated in accordance to RAL-GZ-662